

coemar

ProWash 575 LX

**instruction
manual**

1st edition, april 2002

Index

1. Packaging	Page. 3
2. Transportation	.. 3
3. Important safety informations	.. 4
4. Lamp: installation and replacement	.. 5
5. Operating voltage and frequency	.. 7
6. Installing the unit	.. 8
7. Mains connection	.. 9
8. Signal connection	.. 10
9. Powering up	.. 11
10. DMX addressing	.. 12
11. Display panel functions	.. 13
11.1 Powering up ProWash 575 LX without movement	.. 14
11.2. Resetting the counter	.. 15
11.3. test	.. 15
12. DMX 512 signal functions	.. 16
13. Aligning the lamp in the optical path	.. 18
14. Automatic repositioning function	.. 19
15. Opening up the projector housing	.. 20
16. Altering the operating voltage and frequency (reserved to technical staff only)	.. 21
16.1 Selecting the voltage on the autotransformer	.. 21
16.2. Selecting the frequency on the power supply	.. 22
17. Automatic internal functions	.. 23
18. Maintenance	.. 23
19. Electronic motor alignment	.. 24
20. Error messages	.. 25
21. Spare parts	.. 25

Congratulations on havin purchased a **coemar**, product .You have assured yourself of a fixture of the highest quality, both in the componetry and the technology used. We renew our invitation to fill out the form on the previous page, to expedit any request of informations or spares (in case you encountered complications either during or subsequent to installation), This will allow your **coemar** service center to provide the needed help with the utmost speed and efficiency.

1. Packaging

Following the operating procedures and instructions outlined in this manual, you will ensure your fixture to work at its best for years to come.

Open up the packaging and make sure that no part of the fixture has substained any kind of damage during transportation. In case of damage, immediatly contact your carrier by phone or fax, announcing the shipment of a formal written complaint..

packing list

Make sure the pakage contains:

1 **ProWash 575 LX**

1 this instruction manual

2. Transportation

ProWash 575 LX must be transported exclusively using the original package or a custom made flight case.

To obtain a suitable case, you need to follow a few indications on how to lock the articulated movements of the **ProWash 575 LX**. while being transported

To this purpose, the illustration below shows a section of the case **coemar** suggests for the ensuring of the fixture and its moving parts by means of a polyethylene mold.

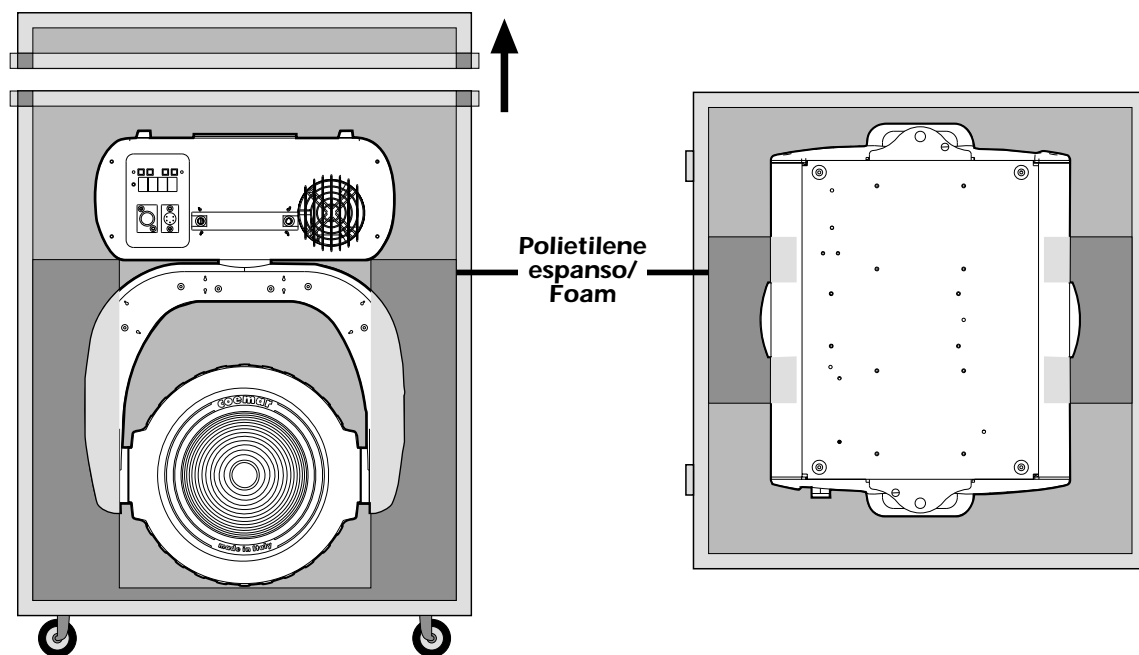

3. Important safety informations

Fire prevention

1. **ProWash 575 LX** uses a Philips 575 MSD or 575 MSR/2 lamp; the use of a different lamp may result in the damaging of the fixture and cause the voiding of the guarantee.
2. Never install the fixture on flammable surfaces.
3. Minimum distance from any flammable material: 0,5 m.
4. Minimum distance from the closest illuminable surface 2 m.
5. Replace damaged or blown fuses only with others of identical size and value, referring if necessary to the schematic diagram.
6. Connect the projector to main power via a thermal magnetic circuit breaker..

Prevention of electric shock:

1. High voltage is present in the internals of the unit; disconnect from mains supply prior to perform any operation involving contact with the internal components of the projector, including lamp replacement
2. For mains connection, strictly adhere to the instructions outlined in section 7 of this manual.
3. Given its high level of technology, **ProWash 575 LX**, needs the intervention of specialized personnel for all service applications. Always refer to you **coemar** center.
4. A good ground connection is essential to the proper functioning of the fixture. Never operate the unit without a proper ground connection.
5. Never install the fixture where it may be exposed to rain, or in extremely humid ambients. A constant supply of circulating air is essential

Protection against ultraviolet radiations:

1. Never turn on the lamp if any of the lenses, filters or plastic housings is damaged; their shielding action is effective only if they are in perfect conditions.
Never look directly into the lamp when it is operating.

Safety:

1. The projector should always be installed with bolts, clamps, and other fixings which are suitably rated to support the weight of the unit.
2. Always use a secondary safety chain of a suitable rating to sustain the weight of the unit in case of the failure of the primary fixing point.
3. The external surfaces of the unit at various points may exceed 80°C. Never handle the unit until at least 10 minutes have elapsed since the lamp was turned off.
4. Always replace the lamp if any physical damage is evident.
5. Never install the fixture in an enclosed area lacking sufficient air flow; the ambient temperature should not exceed 45°C.
6. A hot lamp may explode. Always wait for at least 10 minutes to elapse after the unit has been turned off prior to attempting to replace the lamp.
Always wear suitable hand protection when handling lamps.

Protection rate against penetration by solids and liquids:

1. The projector is classified as ordinary appareil. Its protection rate against penetration by solid and liquid bodies is IP 20

4. Lamp: Installation and replacement

ProWash 575 LX utilizes a Philips 575 MSD or Philips 575 MSR/2 575W lamp with base GX 9,5. The lamp is available for purchase through **coemar**'s sale network

Philips 575 MSD		Philips 575 MSR/2	
coemar cod.	105215	coemar cod.	105245/2
power	575 w	power	575 w
luminous flux	43.000 lm	luminous flux	49.000 lm
colour temperature	6000° K	colour temperature	7.200° K
base	GX 9,5	base	GX 9,5
approximate life	3000 ore	approximate life	1000 ore

Attention

Disconnect mains prior to opening up the unit.

The fixture's internal temperature can reach 250° C after 5 minutes with a maximum peak of 350° C; ensure that the lamp is cold prior to attempting removal. The fixture should be allowed to stand and cool for 10 minutes prior to its removal.

The lamps are part of the mercury vapour family of discharge lamps and must be handled with great care. The lamps operate at high pressure, and the slight risk of explosion exists if operated over their recommended lamp life.

We recommend, therefore, that the lamp be replaced within the manufacturer's specified lamp life..

Installing the lamp

1) By means of a screwdriver, remove the 2 screws (**A**) affixing the lamp assembly, placed on the back of the fixture.

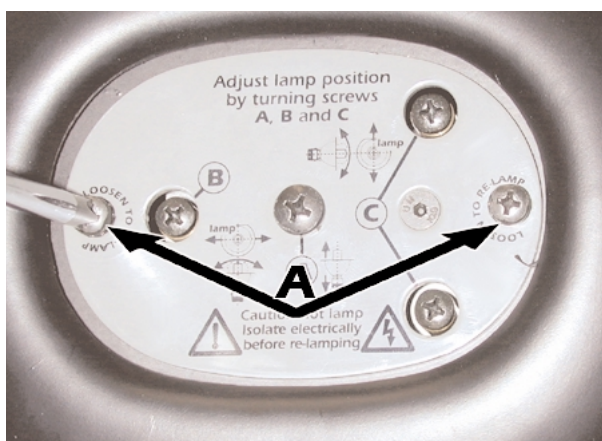

2) Extract the lamp assembly (**B**)

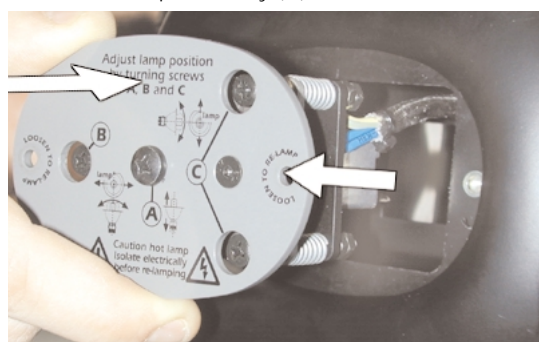

3) Locate the lampholder (**C**)

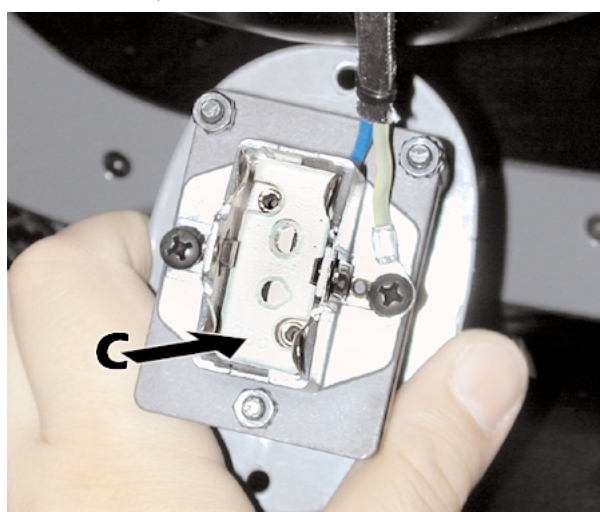

English

4) Insert the new lamp.

The lamp is manufactured from quartz glass and should be handled with care; always adhere to the instructions supplied in the lamp's packaging. Never touch the glass directly, use the tissue provided in the lamp's packaging. The GY 9,5 lampholder is asymmetrical in construction, with one lamp pin larger than the other. DO NOT USE UNDUE FORCE. In case of difficulty, inspect for physical damage and then repeat the installation procedure.

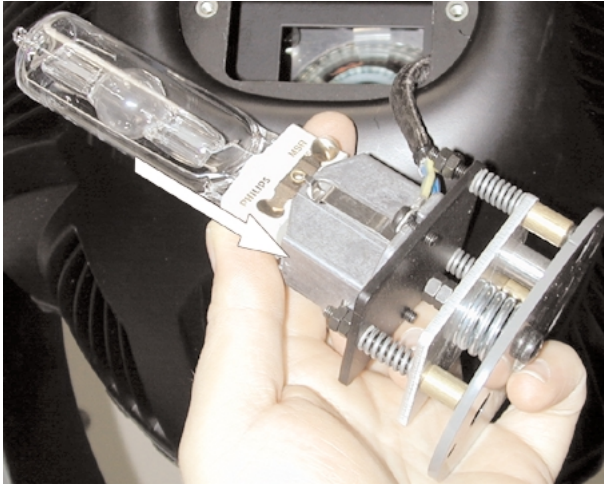

5) Slip the lamp assembly back into its slot and replace the 2 screws (A) previously removed.

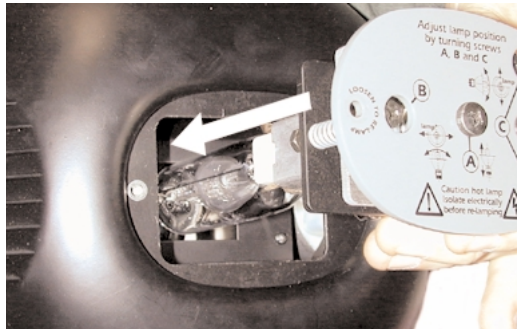

Attention: we recommend to run a lamp alignment routine after every lamp replacement, to keep the dichroic filters inside the fixture from overheating; Refer to chapter 13 of this manual for more detailed instructions.

5. Operating voltage and frequency

The fixture can operate at 115-208, 230 or 240V .at 50 or 60 Hz; **coemar** usually selects (unless specific request is made), tension at 230 V and frequency at 50 Hz. The selected voltage and frequency are barred on the print on the base of the fixture, as shown in the picture below.

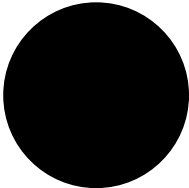
factory set main at:	
	
<input type="checkbox"/> 100V	<input type="checkbox"/> 115V
<input type="checkbox"/> 208V	<input checked="" type="checkbox"/> 230V
<input type="checkbox"/> 240V	
<input checked="" type="checkbox"/> 50Hz	<input type="checkbox"/> 60Hz

If this preset does not correspond with the conditions in your particular country of operation, follow the instructions in the appropriate section of this manual: **16. Altering the operating voltage and frequency.**

Incorrect frequency and voltage selection will detrimentally affect the operation of the projector.

6. Installing the unit

mounting

ProWash 575 LX comes with four rubber feet mounted on the base, allowing it to stand on any kind of surface. It can be installed both on the ground and upside down, hanging from the ceiling. In case of suspended installation, we recommend the use of a proper structure, able to stand the weight of the unit.

Said structure, besides being sufficiently robust, must also not be affected by the slight oscillating movement provoked by **ProWash 575 LX** while operating; provide therefore to make your trussing rigid enough.

The 2 mounting holes Ø13 mm (**A**) on the base of the **ProWash 575 LX** allow the projector to be mounted by means of c-shaped clamps.

safety chains

The use of a safety chain fixed to the **ProWash 575 LX** and to the primary suspension structure is highly recommended to protect against the accidental failure, however unlikely, of the primary suspension point.

If using an aftermarket safety chain not manufactured by **coemar**, ensure that it is of a sufficient rating to hold the weight of the unit.

The safety chain is attached by means of the two holes **B** located in the base of the unit as shown in the diagram.

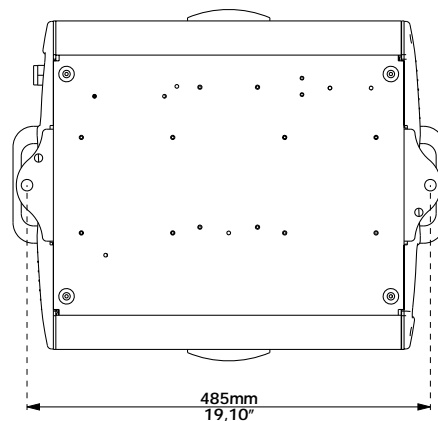
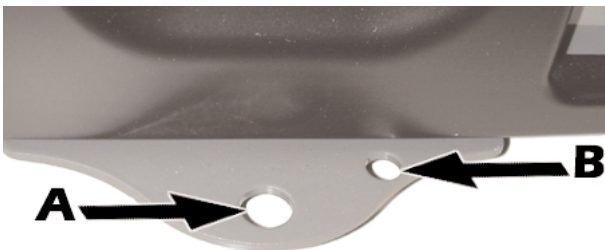

movement

The projector has an articulated movement of 530° in the base and 284° through its yoke; **DO NOT** obstruct the articulated movement in any way.

protection against liquids

The projector contains electric and electronic components that must not come into contact with water, oil, or any liquid.

risk of fire

Each fixture produces heat and must be installed in a well-ventilated position. The minimum recommended distance from flammable material is: 0.5m. Minimum distance from the object being illuminated is: 2m.

forced ventilation

You will note that the projector's housing contains several air entry points and fan outlets, positioned both on the head and the base of the unit; under no circumstances should any of these points be obstructed!

Questo comporterebbe il surriscaldamento dell'apparecchio, con il rischio di comprometterne seriamente il funzionamento. Obstruction of any of these points will result in the over-heating of the unit, detrimentally and seriously affecting the proper operation of the **ProWash 575 LX**.

ambient temperature

Do not install the fixture where there's lack of a constant air flow; ambient temperature should never exceed 35°C.

7. Mains connection

cable preparation

The mains cable provided is thermally resistant, complying to the most recent international standards, approved by VDE and conformed to these following legislations: IEC 331, IEC 332 3C, CEI 20 35.

NOTA: In case of cable replacement, similar cable with comparable thermal resistant qualities must be used exclusively (cable 3x1,5, external \varnothing 10 mm, rated 300/500V, tested to 2KV, operating temperature -40° $+180^{\circ}$, **coemar** cod. CV5309).

mains connection

ProWash 575 LX can operate at 115V-208V-230V-240V at 50 or 60Hz (the desired tension and frequency must be selected as described in paragraph 5 of this manual).

Prior to powering up the fixture, make sure the model you own matches the requirements of your mains supply. For connection purposes, ensure your plug is of a suitable rating:

at 230V, 8 amps

at 115 V. 11Amps

Locate the mains cable which exits the base of the unit and connect as shown below:

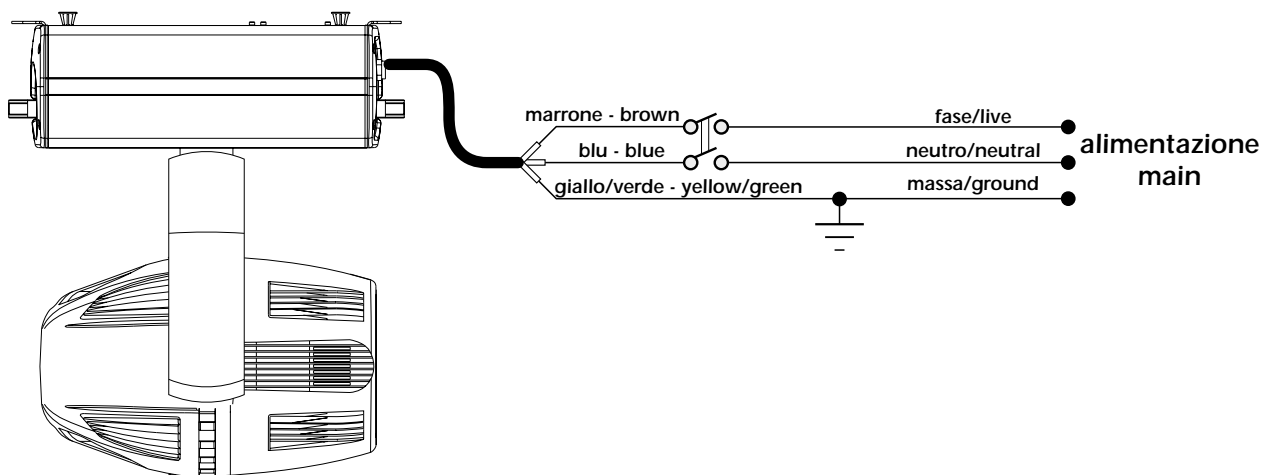

protection

The use of a thermal magnetic circuit breaker is recommended for each **ProWash 575 LX**.

A good earth connection is essential for the correct operation of the fixture. Strict adherence to regulatory norms is strongly recommended.

8. Connessione di segnale

Control signal is digital and is transmitted via two pair screened $\varnothing 0,5$ cable.

Signal type is **DMX 512**, conforming to international standard; in order to reduce production costs and to allow easy worldwide availability of parts; **coemar** utilises XLR 3 plugs and sockets for signal connection. Pin connection conforms to international standards:

pin 1= screening 0 V

pin 2= data -

pin 3= data +

In case your mixer uses XLR-5 plugs and sockets, pins number 4 and 5 must be left disconnected.

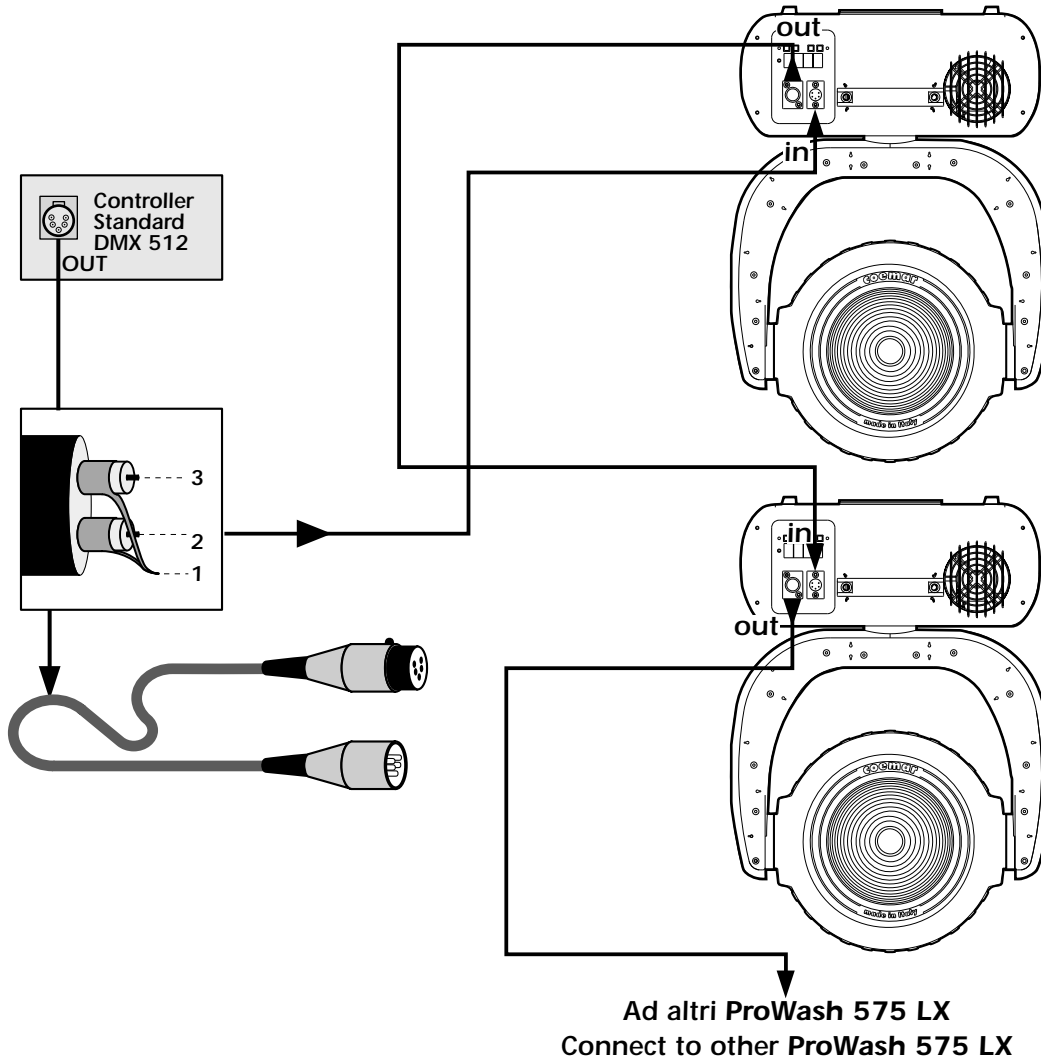

The conductors must not have any contact between them or the connectors' metallic case.

NOTE: The XLR 3/5 cannon's case must absolutely not be connected.

9. Alimentazione

After having gone thoroughly through the procedures so far described, proceed to power up your **DMX 512** mixer, which will control the **ProWash 575 LX**; Subsequently connect the fixture to mains supply, and turn it on by means of the **power** switch. Once turned on, the projector will run the motor reset routine; this procedure, will last a few seconds, allowing the step motors to reach their default positions before following the mixer's commands.

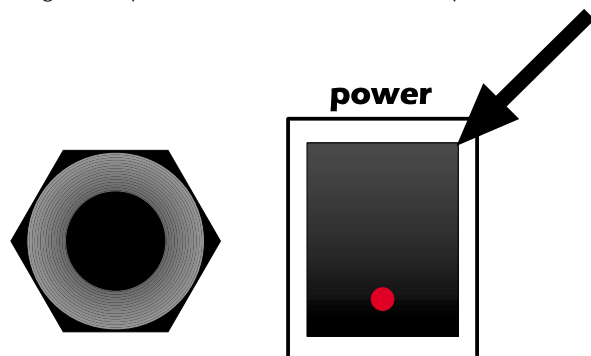

DMX display

The dmx display on the base of the fixture lights up to indicate the **DMX 512** signal sent by the mixer is being correctly received.

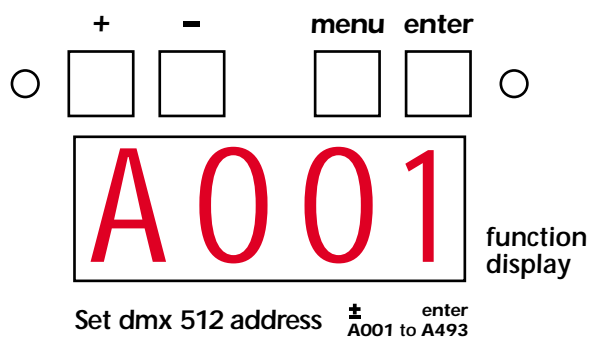

If the display is blinking, the fixture is not receiving any signal; check cables, connections and see if the mixer is functioning properly.

10. DMX addressing

Every fixture uses **16** DMX channels for its complete operativity when controlled by a **DMX 512** mixer (see chapter **12. DMX 512 signal functions** for further informations)

DMX encoding

To make sure the control signal is correctly sent out and received, a brief encoding operation is needed to be run on every projector; any number between 1 and 496 can be generated on the display of the **ProWash 575 LX**.

When turned on, the fixture's display shows by default **A001** which indicates the address **DMX 1**; this projector will respond to the command sent by channels **1** to **16** of the **DMX 512** mixer; following this rule, the second fixture will be addressed as **17**, the third as **33** and so on until the last **ProWash 575 LX**.

changing the DMX address

- 1) press the **+** or **-** buttons until you reach the desired **DMX** number; the digits on the display start blinking, to indicate an unregistered variation.

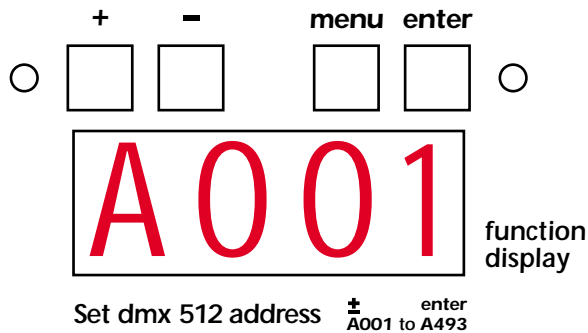

- 2) Press now the **enter** button to confirm your selection; the digits stop blinking, the fixture now responds to the newly entered **DMX 512** address.
- 3) For a more accurate explanation on the functioning of every **DMX 512** channel, please refer to chapter **12. DMX 512 signal functions**

IMPORTANT NOTES: keeping the **+** or **-** buttons pressed you'll pass through the available channels at high speed, for a faster selection.

Pressing the **-** minus you could by mistake select a number of DMX channel not included in those generated by your mixer, for instance 500; in this case the display will show to have problems receiving data (because there aren't any), and the fixture itself will become a lot slower in responding to your commands; proceed then to generate data on that address, or vary once again the DMX address of your **ProWash 575 LX**.

11. Display panel functions

The display panel on the base of the **ProWash 575 LX** is used to display and set function information and various parameters and can enhance the operation of the projector to suit your particular application.

Altering the **coemar** factory settings may vary the functioning of the projector, causing it not to respond to external **DMX 512** signal. Please read and familiarise yourself with the following information very carefully before altering any selections. The  symbol is used throughout the following table to indicate the action of pressing the particular button referred to in the accompanying text.

Display functions diagram:

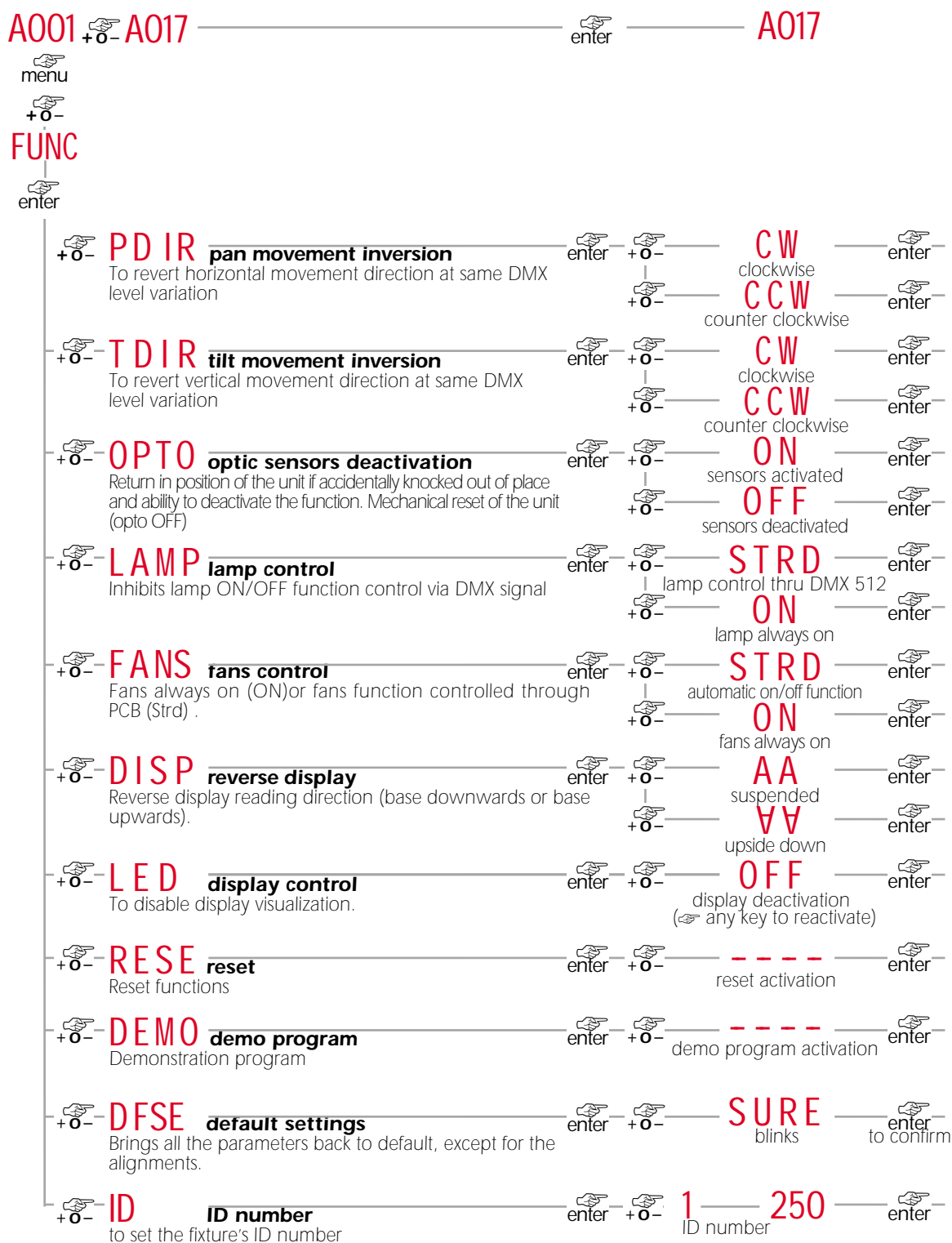

English

Display measurements diagram:

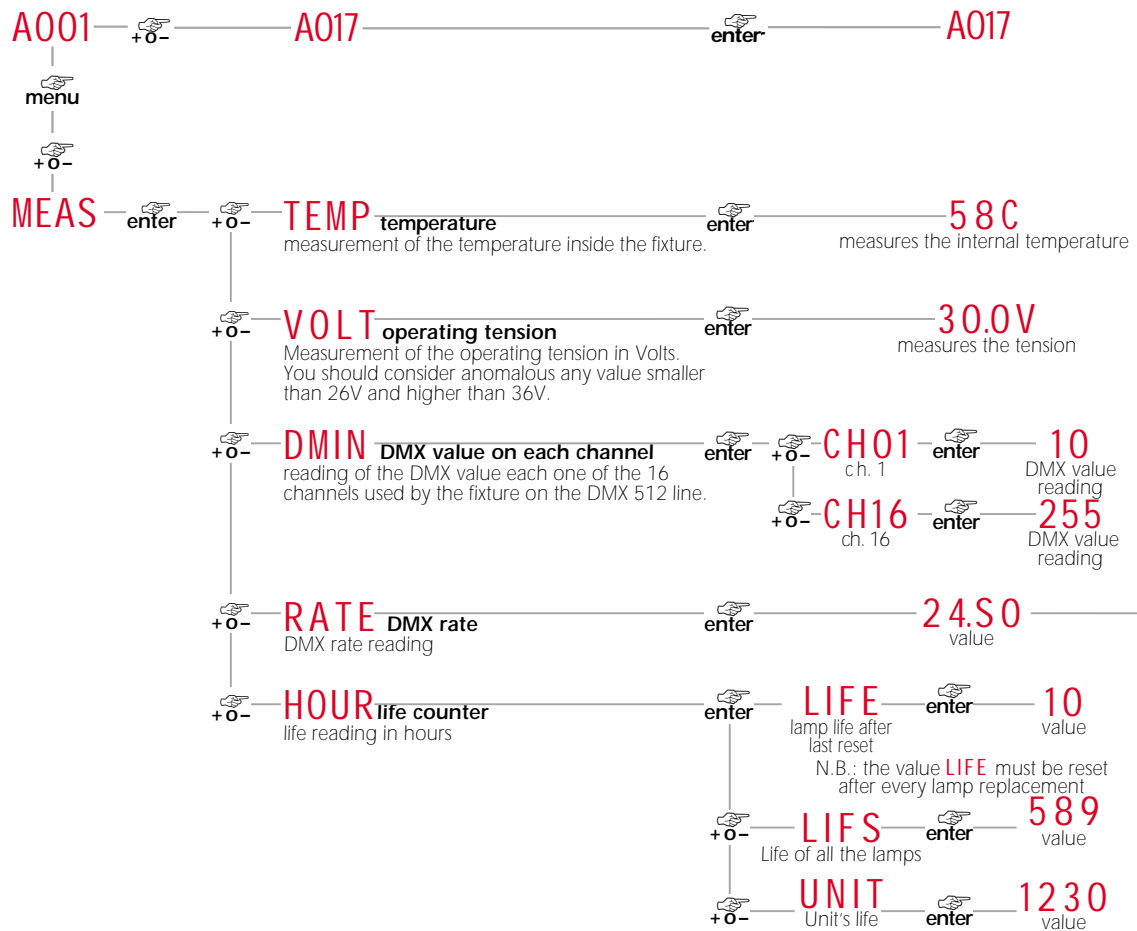

11.1. Accensione di ProWash 575 LX senza il movimento

La funzione vi può essere utile nel caso che dobbiate accendere **ProWash 575 LX** all'interno del flight case o installato in una struttura per inserire un nuovo indirizzo o variare alcuni parametri senza che l'apparecchio si muova.

1) Accendete il proiettore tenendo premuti contemporaneamente i tasti **enter**, **menu** e **-**

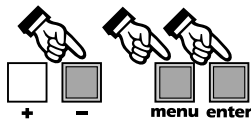

il proiettore esegue la procedura di reset di tutti i motori esclusi quelli dei movimenti pan e tilt, che restano fermi non alimentati.

- 2) Potete variare l'indirizzo DMX, o qualsiasi parametro accessibile dal menu senza che il proiettore si sia mosso.
- 3) Per tornare al funzionamento normale di **ProWash 575 LX** dovete spegnere e riaccendere il proiettore, tramite il tasto di alimentazione **power**.

12. DMX 512 signal functions

If you followed all the procedures described so far, the 16 channel of the **ProWash 575 LX** will be controlled by your **DMX 512** mixer as specified in the following diagram

channe	function	type of control	effect	decimal
1	base (pan) coarse	proportional	coarse control of the base movement	0-255
2	base (pan) fine	proportional	fine control of the base movement	0-255
3	yoke (tilt) coarse	proportional	coarse control of the yoke movement	0-255
4	yoke (tilt) fine	proportional	fine control of the yoke movement	0-255
5	movement speed	step	standard (fast)	0-10
		step	ultra fast movement (best for programming)	11-25
		proportional	vector mode from fast to slow	26-127
		proportional	tracking mode from fast to slow	128-247
		livello unico	tracking mode - slow	248-255
6	dimmer	step	closed	0-7
		proportional	gradual adjustment of the dimmer intensity from 0 to 100%	8-255
7	shutter, strobe	step	shutter closed	0-9
		proportional	synchro strobe effect from slow to fast	10-66
		step	shutter open	67-68
		proportional	pulse effect in sequence, close slow open fast (adjustment from slow to fast)	69-125
		step	shutter open	126-127
		proportional	pulse effect in sequence, close fast open slow (adjustment from fast to slow)	128-184
		step	shutter open	185-187
		proportional	random strobe effect from slow to fast	188-244
		step	shutter open	245-255
8	beam angle	step	spot	0-9
		proportional	from narrow angle (spot) to wide angle (flood)	10-255
9	conversion filter "par effect"	step	no filter	0-9
		proportional	beam shaping (par effect) from 0 to 180°	10-230
		step	CTO conversion filter	231-255
10	colour wheel	step	white	0-7
		step or proportional depending on channel 14	colour 1	8-27
		step or proportional depending on channel 14	colour 2	28-47
		step or proportional depending on channel 14	colour 3	48-67
		step or proportional depending on channel 14	colour 4	68-87
		step or proportional depending on channel 14	colour 5	88-107
		step or proportional depending on channel 14	colour 6	108-127
		proportional	forwards rainbow effect from fast to slow	128-190
		step	no rotation	191-192
		proportional	backwards rainbow effect from slow to fast	193-255
11	cyan	step	white, no colour	0-9
		proportional	proportional colour control from white to cyan	10-255
12	magenta	step	white, no colour	0-9
		proportional	proportional colour control, from white to magenta	10-255
13	yellow	step	white, no color	0-9
		proportional	proportional colour control from white to yellow	10-255
14	colour positioning mode	step	the colours on the wheel are centered on the optical	0-125
	effects channel 10	step	colour positioning becomes proportional	126-255

15	black-out activation synchronized to movement and color positioning	step	no effect	0-249
		step	black-out activates automatically, synched to the fixture's movement and color positioning	250-255
16	lamp on/off, motor	step	park, no function	0-10
		step	lamp off	11-29
		step	pan and tilt reset	30-65
		step	all motors reset except dimmer, pan and tilt (only once)	66-100
		step	all motors reset except dimmer (only once)	101-135
		step	all motors reset (only once)	136-170
		step	silent fans (if allowed by the internal components)	171-249
		step	lamp on	250-255
lamp off function can be inhibited via DMX by acting on the fixture's back panel				
NOTE: lamp off and reset functions have a 6 seconds delay to prevent accidental activation				
NOTE: lamp on/off function can be affected only by a command of opposite value				

13. Aligning the lamp in the optical path

The alignment of the lamp in the optical path can be adjusted by acting on the 3 screws placed on the back of the fixture on the lamp assembly.

The procedure should be undertaken to avoid the possible overheating of internal components due to incorrect focusing of the beam onto components which are not designed to be exposed to this..

Alignment procedure

Alignment is effected by manipulating the 3 adjusters, **A**, **B** and **C** simultaneously; with the lamp on and blackout shutter dimmer and no filters placed in the optical path.

The procedure centres any hotspots (adjuster **B**) and then flattens the beam to produce an even beamspread (adjusters **A** and **C**).

When the lamp is not aligned, you will notice a brighter spot: that is the position of the lamp bulb into the beam; by acting on the 3 screws you'll be able to adjust the beam's uniformity (adjuster **A**) and the position of the bright spot into the beam (adjusters **B** and **C**), making it as centered as possible.

Vertical adjustment

Adjuster (**C**) acts on a lever and spring assembly to position the lamp vertically within the reflector. Rotate the adjuster (**B**) until the beam produced is as required.

Horizontal adjustment

Adjuster (**B**) acts on a lever and spring assembly to position the lamp horizontally within the reflector. Rotate the adjusters until the beam produced is as required.

Axial adjustment

The effect of moving adjuster (**A**) is to position the lamp axially within the reflector.



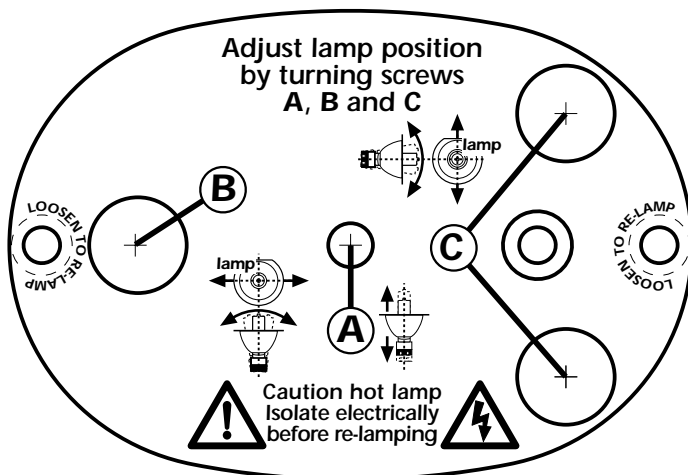



Rotate the adjuster (until the beam produced is flat and even).



14. Automatic repositioning features

An encoder system based on 4 position indicators allows the **ProWash 575 LX** to return to its correct position if it is accidentally moved during operation.

This is particularly useful if the projector is to be mounted on the floor in a position where the performer or artist or technician may accidentally bump the unit..

A001  **menu**  **+0-** **OPT0** **optic sensor deactivation**  **enter**  **+0-** **ON**  **enter**
 Return in position of the unit if accidentally knocked out of place and ability to deactivate the function. Mechanical reset of the unit (opto OFF).
 |
 **+0-** **OFF**  **enter**
 sensors activation
 sensors deactivation

15. Opening up the projector housing

The fixture allows to perform a complete inspection of its internal components simply by removing the plastic housing as shown below/

Attention

Disconnect from mains prior to opening up

- 1) with a proper screwdriver remove the screws that lock the two halves of the housing together

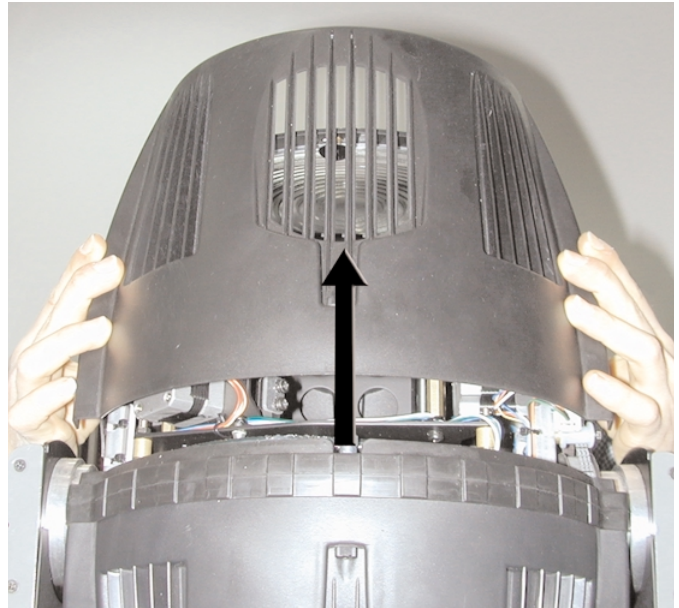

- 2) Lift the front half of the housing to gain access to the internal components of the fixture.



16. Altering the operating voltage and frequency (Reserved for technical staff only)

If the operating voltage and frequency as preset by **coemar** does not correspond to that of the country in which you are operating, you may alter the preset by following the instructions in the paragraphs which follow.

An error in voltage or frequency selection may seriously compromise the correct functioning of the projector.

16.1 Selecting the voltage on the autotransformer

1) Remove the screws on the base of the fixture, as shown in the picture below, then simply lift the covers to access the internal components of the **ProWash 575 LX**.

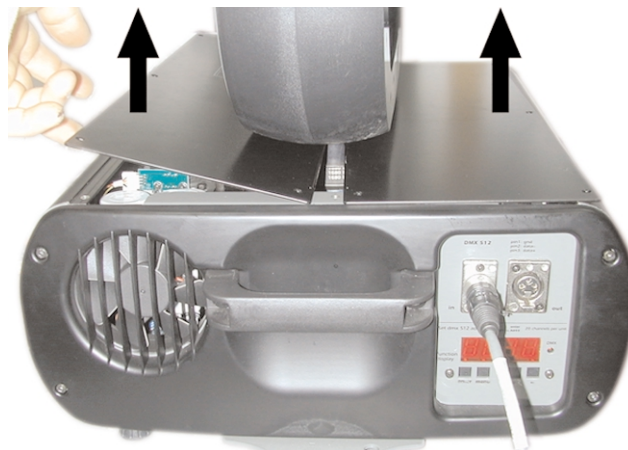



2) Locate the autotransformer.

3) Select the tension among 115, 208, 230 and 240V disconnecting cable n° 22 and moving it on the desired tension. For a correct selection, refer to the label on the autotransformer.

Cables n° 4, 23, 24 e 25 should not be moved from their position for any reason.

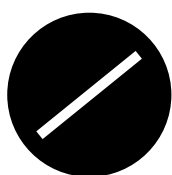
4) If the tension you chose is 115V replace the 8 Amps T fuse, ideal for a selection at 208/230/245 V, with a 15 Amps T one. the fuse holder is located on the base of the fixture. You will find the replacement fuse in a plastic bag attached to this present manual



T8A @230V
T15A @115V

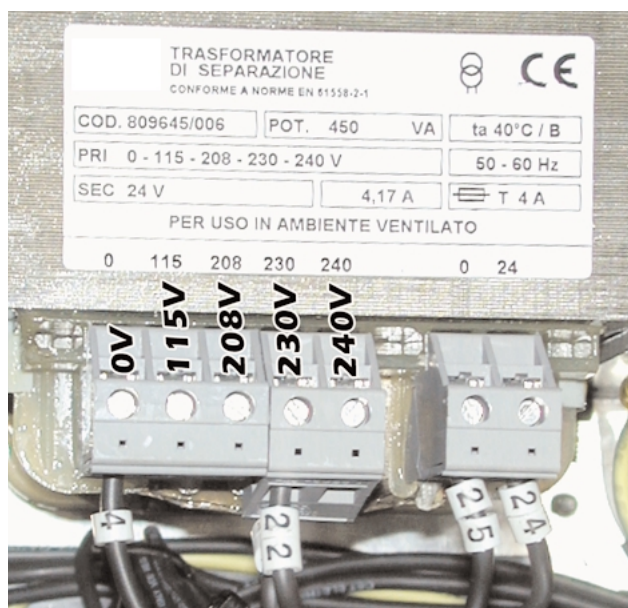

5) Proceed now to select the frequency as described in the next paragraph, or replace the covers and close the base.

6) Cross on the label located on the base of the **ProWash 575 LX** the tension you just selected, as shown in the picture on the following page

English

16.2. Selecting the frequency on the power supply

- 1) Locate the power supply in the base of the unit.
- 2) Select the required frequency from between 50 and 60Hz by moving cable n° 11 to the correct option. To ensure correct positioning of the cable, refer to the label located on the power supply.

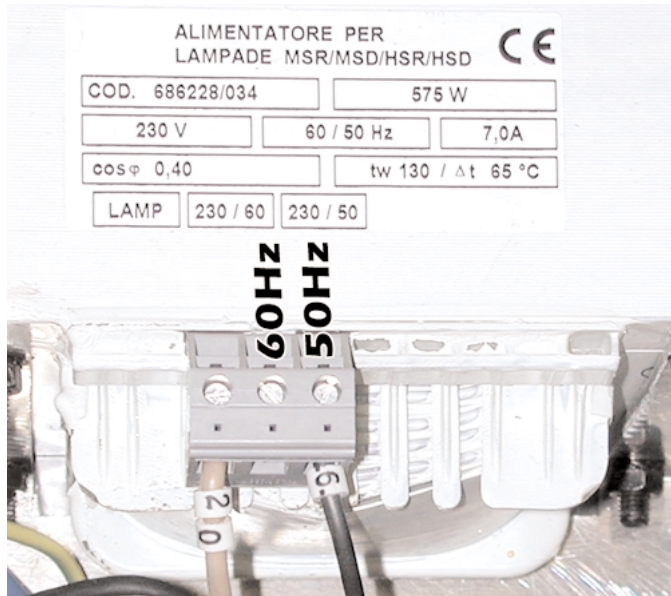

Cable n° 20 should not be moved from its position for any reason.

- 3) Replace the cover and refasten the 10 screws
- 4) Cross on the label located on the base of the **ProWash 575 LX** the tension you just selected, as shown in the picture.

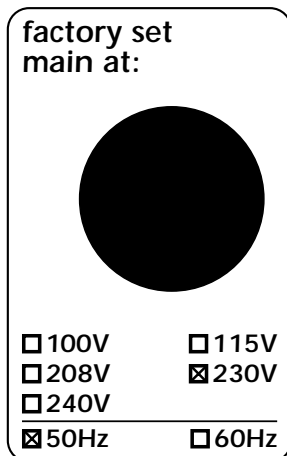

17. Automatic internal functions

ProWash 575 LX, has hidden automatic functions that may not be noticeable, but that contribute nonetheless to preserve its functioning after years and on the most critical environmental conditions

on-board hot-strike timer

This on-board feature ensures that the operator cannot re-ignite the lamp until 8 minutes have passed since the lamp was switched off, protecting the ballast and the ignitor from prolonged use in less-than-ideal conditions. The device will repeatedly try to ignite the lamp for 20 seconds every minute for 8 minutes. If the lamp still does not strike, the device will then stop its attempts in order to protect the lamp ignition circuit, considering the lamp as if at the end of its life. In this case the display will show **LAER** (lamp error).

This feature further protects the lamp from possible damage due to voltage spikes which may occur at this time.

NOTE: It is anyway suggested to discontinue the use of the fixture once the lamp has reached the end of its life, and proceed to replace it as soon as possible.

thermal protection

Two thermal sensors in the body and base of the **ProWash 575 LX** protect the unit against overheating.

The thermal sensors operate by removing voltage to the lamp if the ambient temperature rises above a preset maximum due to either less than ideal air circulation around the fixture or in the event of cooling fan failure.

automatic realignment

An internal 4 point encoder system allows the **ProWash 575 LX** to return to its correct position in case the unit is accidentally knocked out of alignment whilst operating. This is particularly useful if the projector is to be mounted on the floor in a position where the performer or artist may accidentally bump the unit.

NOTE: It is possible to deactivate the device if desired (see chapter **11 display panel functions OPTO OFF**).

18. Maintenance

Whilst every possible precaution has been taken to ensure the trouble-free operation of your **ProWash 575 LX**, the following periodic maintenance is highly recommended. Prior to undertaking any maintenance procedure, make sure the fixture is disconnected from mains power.

Attention

Disconnect mains power prior to opening the housing!

To gain access to the internal components of the fixture, refer to chapter **15. Opening up the projector housing** of the present manual.

Periodic cleaning

Lenses and reflectors

Even a fine layer of dust can reduce the luminous output substantially. Regularly clean all lenses and the reflector using a soft cotton cloth, dampened with a specialist cleaning solution.

Fans and air passages

The fans and air passages must be cleaned approximately every 6 weeks; the period for this cleaning will depend, of course, upon the conditions in which the projector is operating. Suitable instruments for performing this type of maintenance are a brush and a common vacuum cleaner or an air compressor.

Periodic maintenance

Lamp

The lamp should be replaced if there is any observable damage or deformation due to heat. This will avoid the danger of the lamp exploding.

Mechanicals

Periodically check all mechanical devices for wear and tear; gears, guides, belts, etc, replacing them if necessary. Periodically check the lubrication of all components, particularly the parts subject to high temperatures. If necessary, lubricate with a suitable lubricant, available from your **coemar** distributor.

Electrical components

Check all electrical components for correct earthing and proper attachment of all connectors, refastening if necessary.

Fuse replacement

Locate the protection fuses on the base of the projector.

Use a multimeter to check the condition of the fuses, replacing them with fuses of similar value if required.

19. Allineamento elettronico dei motori































RESERVED TO TECHNICAL STAFF ONLY

The display panel on the **ProWash 575 LX** allows for the electronic alignment of the projector's motors. This procedure is performed by **coemar** at the factory. It may be useful to perform this procedure in the case of internal components being replaced. Altering the factory settings may radically alter the functioning of the projector. Carefully read all of the following prior to attempting any changes.

electronic alignment

IMPORTANT NOTE: the electronic alignment procedure will be possible to perform only if the fixture is correctly receiving the DMX 512 signal.

- 1) Press the **menu** button
- 2) Press the **+** or **-** buttons until **RESE** (reset) appears on the display.
- 3) Prss simultaneously the **enter** and **menu** buttons, holding them down for at least **30 seconds**. The effect motors begin the reset procedure; the display shows **---** for few seconds, confirming you have entered the alignment section.

	PNAL pan pan motor alignment	 enter	0128	 + 0-	es.	0120	 enter
 + 0-	TLAL tilt tilt motor alignment	 enter	0128	 + 0-	es.	0120	 enter
 + 0-	SHAL shutter shutter alignment	 enter	0128	 + 0-	es.	0120	 enter
 + 0-	DIAL dimmer dimmer alignment	 enter	0128	 + 0-	es.	0140	 enter
 + 0-	FIAL filters filters alignment	 enter	0128	 + 0-	es.	0130	 enter
 + 0-	COAL colours colours positioning motor alignment	 enter	0128	 + 0-	es.	0125	 enter
 + 0-	CYAL cyan Cyan alignment	 enter	0128	 + 0-	es.	0135	 enter
 + 0-	MGAL magenta magenta alignment	 enter	0128	 + 0-	es.	0132	 enter
 + 0-	YEAL yellow yellow alignment	 enter	0128	 + 0-	es.	0127	 enter
 + 0-	END end to end the alignment procedure, record eventual changes and go back to normal functioning.					A001	

simultaneously

 +  **0128**

NOTE:

To speed up the alignment procedure, press the **+** and **-** keys simultaneously to cause the display to jump straight to 128.

20. Error messages

MBER:	COMMUNICATION error This message indicates that the motherboard within the unit is not communicating properly with the control source. Check the connectors located on both boards.
OPER:	PAN ENCODER error This message indicates that there is a problem with the PAN encoders. Check the sensors on the encoder wheel located near the pan movement motor, as well as the relevant cabling.
OTER:	TILT ENCODER error This message indicates that there is a problem with the TILT encoder locate on the fixture yoke. Check the sensors on the encoder wheel located near the pan movement motor, as well as the relevant cabling.
SNER:	LINE SYNCHRONISATION error Check and replace opto-isolator U9.
LAER:	LAMP error The lamp has turned off unexpectedly, without any signal from the controller to do so. The system may have exceeded the allowable number of attempts to ignite the lamp (7) after which number the system is designed to protect ignitor, cabling and the lampholder by reducing the incidence of lamp ignition voltages to these components. Check and eventually replace the lamp if it is faulty, damaged, or has exceeded its lamp life.
EPER:	EEPROM error The EEPROM is either defective or absent; refer to your coemar service centre for a replacement component.
DTER:	DATA error The initial parameter settings are incorrect or corrupt; the projector has reloaded its factory default settings. Turn the projector off and on again. Should the error reoccur, refer the unit to your authorised coemar service centre to have the EEPROM check and possibly replaced.
SRER:	RESET SENSOR CIRCUIT error Check the cabling and sensors on the COLOUR and EFFECT wheels; the sensor and circuit board indicate an error.
COER:	COLOUR WHEEL POSITION error Check the functioning and correct positioning of the magnetic colour wheel sensor.
EFER:	DIFFUSION FILTER WHEEL POSITION error Check the functioning and correct positioning of the magnetic effects wheel sensor.
ER20 ÷ ER99:	SYSTEM errors Turn the unit off and on again. If the error persists, contact your authorised coemar service centre.
HEAT:	LAMP OVERHEAT indicator The projector is attempting to ignite a lamp which is still too hot to strike. Wait until the lamp has cooled further and then attempt to reignite the lamp.

21. Spare parts

All the components of the **ProWash 575 LX** are available as replacement parts from your authorised **nota**.sales agent. Accurate description of the fixture, model number, and type will assist us in providing for your requirements in an efficient and effective manner.